



Semester Two Examination, 2016

Question/Answer Booklet

**MATHEMATICS
APPLICATIONS
UNITS 3 AND 4**

**Section Two:
Calculator-assumed**

If required by your examination administrator, please place your student identification label in this box

Student Number: In figures

--	--	--	--	--	--	--	--

In words

Your name

Time allowed for this section

Reading time before commencing work: ten minutes

Working time for section: one hundred minutes

Materials required/recommended for this section

To be provided by the supervisor

This Question/Answer Booklet

Formula Sheet (retained from Section One)

To be provided by the candidate

Standard items: pens (blue/black preferred), pencils (including coloured), sharpener, correction fluid/tape, eraser, ruler, highlighters

Special items: drawing instruments, templates, notes on two unfolded sheets of A4 paper, and up to three calculators approved for use in the WACE examinations

Important note to candidates

No other items may be taken into the examination room. It is **your** responsibility to ensure that you do not have any unauthorised notes or other items of a non-personal nature in the examination room. If you have any unauthorised material with you, hand it to the supervisor **before** reading any further.

Structure of this paper

Section	Number of questions available	Number of questions to be answered	Working time (minutes)	Marks available	Percentage of exam
Section One: Calculator-free	8	8	50	53	35
Section Two: Calculator-assumed	13	13	100	98	65
Total				151	100

Instructions to candidates

- The rules for the conduct of Trinity College examinations are detailed in the *Instructions to Candidates* distributed to students prior to the examinations. Sitting this examination implies that you agree to abide by these rules.
- Write your answers in this Question/Answer Booklet.
- You must be careful to confine your response to the specific question asked and to follow any instructions that are specified to a particular question.
- Spare pages are included at the end of this booklet. They can be used for planning your responses and/or as additional space if required to continue an answer.
 - Planning: If you use the spare pages for planning, indicate this clearly at the top of the page.
 - Continuing an answer: If you need to use the space to continue an answer, indicate in the original answer space where the answer is continued, i.e. give the page number. Fill in the number of the question that you are continuing to answer at the top of the page.
- Show all your working clearly.** Your working should be in sufficient detail to allow your answers to be checked readily and for marks to be awarded for reasoning. Incorrect answers given without supporting reasoning cannot be allocated any marks. For any question or part question worth more than two marks, valid working or justification is required to receive full marks. If you repeat any question, ensure that you cancel the answer you do not wish to have marked.
- It is recommended that you **do not use pencil**, except in diagrams.
- The Formula Sheet is **not** to be handed in with your Question/Answer Booklet.

Section Two: Calculator-assumed

65% (97 Marks)

This section has **thirteen (13)** questions. Answer **all** questions. Write your answers in the spaces provided.

Working time for this section is 100 minutes.

Question 9

(4 marks)

The graph and table below show the quarterly sales of bottles of sparkling wine sold by a liquor outlet. The first quarter of 2002 corresponds to $t = 1$, where t is measured in quarters.

Bottles of wine

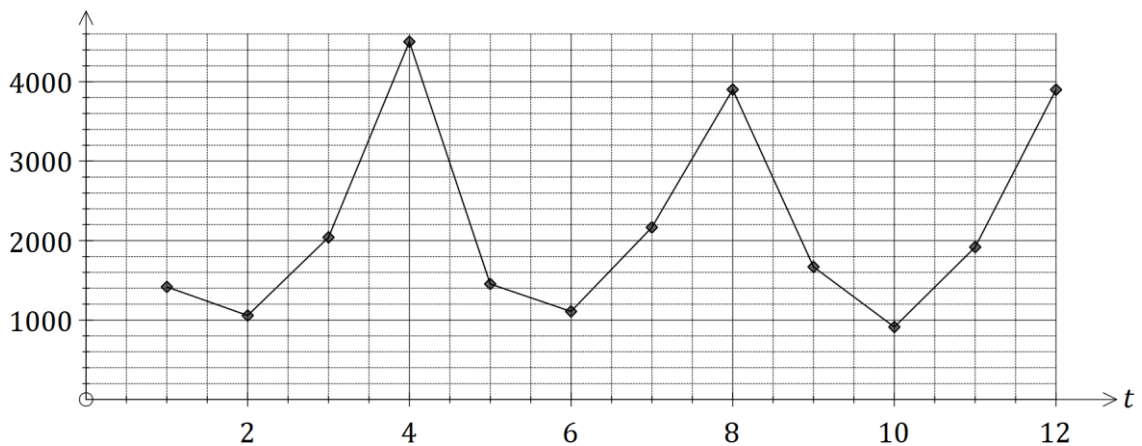

Year	2002				2003				2004			
Quarter	1	2	3	4	1	2	3	4	1	2	3	4
Bottles sold	1417	1057	2041	4503	1454	1108	2166	3903	1669	912	1918	3899

- (a) Determine the value of the centred four-point moving average for the fourth quarter of the year 2003. (2 marks)

- (b) Briefly explain:

- (i) the purpose of calculating simple moving averages for a time series. (1 mark)

- (ii) a feature of the graph that suggests the use of a centred four-point moving average is appropriate for this data. (1 mark)

Question 10

(6 marks)

A survey asked 1660 people whether they believed social classes still exist in Australia. The researchers were interested in whether the belief was dependent on the weekly income of a person. The results are shown in the table below.

	Weekly income			
	Under \$1000	\$1000 - \$1500	\$1500 - \$2000	Over \$2000
Yes	272	413	494	209
No	27	45	41	22
Don't know	33	40	47	17

- (a) Complete the table below, using row or column percentages rounded to the nearest whole number, so that it is possible to determine whether an individual's belief in the existence of social classes is associated with their level of weekly income. (4 marks)

	Weekly income			
	Under \$1000	\$1000 - \$1500	\$1500 - \$2000	Over \$2000
Yes				
No				
Don't know				

- (b) Comment, with reasons, on whether the results of the survey show that the belief that social classes still exist in Australia is dependent on the weekly income of a person. (2 marks)

Question 11

(9 marks)

A reducing balance loan of \$6 590.24 was used to buy a second-hand motorbike. At the end of each month, interest of 0.85% was added to the loan before a repayment of \$580 was made. The table below shows the balance of the loan for the first few months.

Month (n)	Balance at start of month (T_n)	Interest	Repayment	Balance carried forward to start of next month
1	6 590.24	56.02	580.00	6 066.26
2	6 066.26	51.56	580.00	5 537.82
3	5 537.82	A	580.00	B

(a) Write a recurrence relation to model the loan balance in the last column of the table. (2 marks)

(b) Determine the values of A and B in the table. (2 marks)

(c) Determine how many repayments are needed to reduce the balance to zero and show that the total amount of interest paid is \$369.76. (3 marks)

(d) Determine the new monthly repayment for the above loan, if the only change to the loan structure is:

(i) the interest rate increased to 1.1% per month. (1 mark)

(ii) the interest rate remained at 0.85% per month but the loan was repaid over two years. (1 mark)

Question 12

(8 marks)

A report on the expected population growth of eleven Asian cities between 2015 and 2030 included the following statistics.

City	Country	2015 Pop (millions) x	2030 Pop (millions) y
Tokyo	Japan	38	37
Delhi	India	26	36
Shanghai	China	24	31
Mumbai	India	21	28
Dhaka	Bangladesh	18	27
Calcutta	India	15	19
Manila	Philippines	13	17
Tianjin	China	11	15
Jakarta	Indonesia	10	14
Bangkok	Thailand	9	12
Chengdu	China	8	10

- (a) Calculate the correlation coefficient between x and y . (2 marks)
- (b) Re-calculate the correlation coefficient between x and y with the data point for Tokyo removed and explain why it has increased. (2 marks)
- (c) Excluding the data point for Tokyo, determine the equation of the least-squares line to model the relationship between x and y . (1 mark)
- (d) Use the least-squares line to predict the population of Guangzhou (China) in 2030, given that its 2015 population was 12 million, and comment on the reliability of your prediction. (3 marks)

Question 13

(7 marks)

The tasks involved in a project, their immediate predecessors and duration, are shown below.

Task	Duration (minutes)	Predecessor(s)	Earliest Start Time	Float Time
A	14	-	0	
B	12	-	0	
C	10	-	0	
D	20	-	0	
E	4	B, C		
F	17	B, C		
G	7	A, E		
H	6	A, E		

(a) Use the information above to draw the project network below.

(3 marks)

(b) Determine the earliest start time and float time for each task, writing all values in the table above.

(2 marks)

(c) List the tasks on the critical path for this project and state the minimum completion time.

(2 marks)

Question 14

(7 marks)

A car scrapyards had a stockpile of 2 500 old tyres. A recycling program was introduced to reduce the number of tyres in the stockpile by 30% each week, but at the end of each week another 120 tyres were added to the pile from newly scrapped cars.

The number of tyres, T_n , in the stockpile at the start of week n can be modelled by the recursive rule

$$T_{n+1} = T_n \times 0.7 + 120, \quad T_1 = 2500$$

(a) Explain the significance of the 0.7 multiplier in the rule. (1 mark)

(b) Complete the table below, rounding the numbers of tyres to the nearest whole number. (2 marks)

n	1	2	3	4	5	6	7	8	9	10
T_n	2500					753	647	573	521	485

(c) Graph the number of tyres in the stockpile at the start of each week on the axes below. (2 marks)

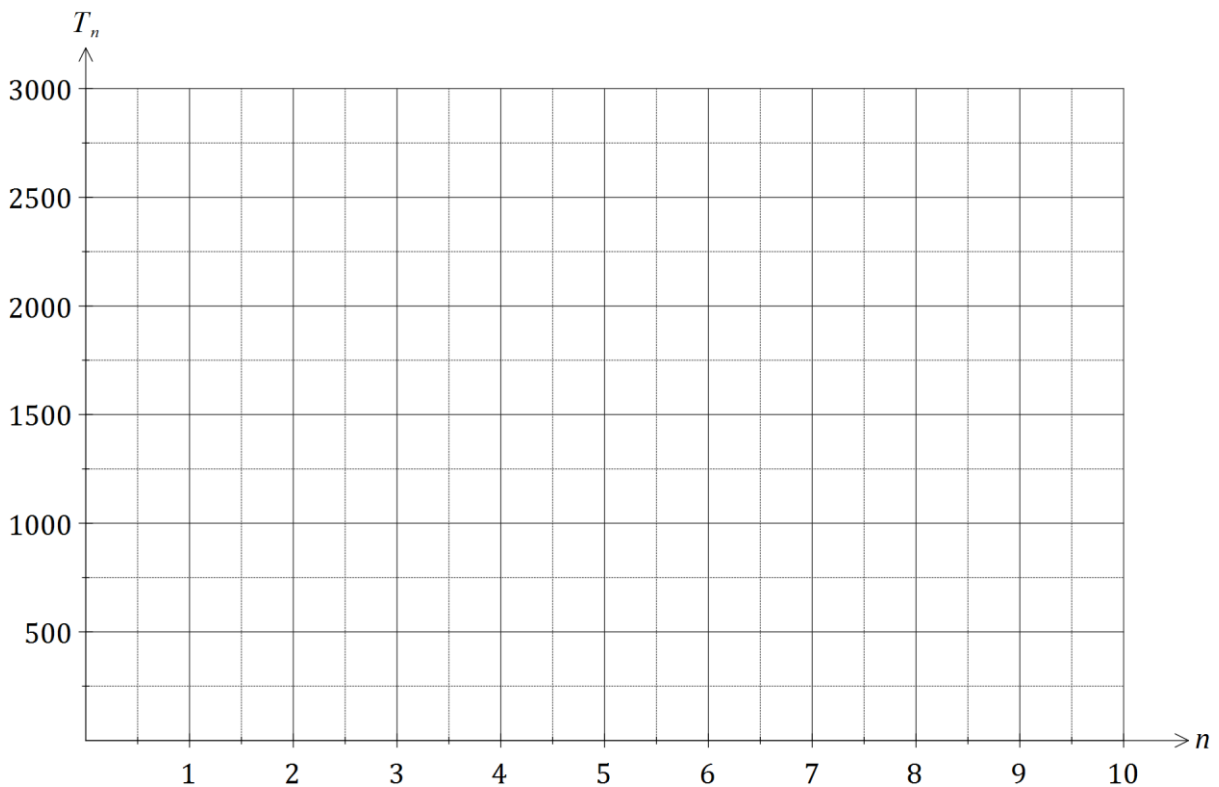

(d) Use the graph to comment on how the number of tyres in the stockpile is changing. (1 mark)

(e) According to the model, how many tyres will the stockpile contain after a large number of years have passed? (1 marks)

Question 15

(10 marks)

The network below shows the times, in minutes, taken by taxis to travel along roads between junctions A, B, C, \dots, L .

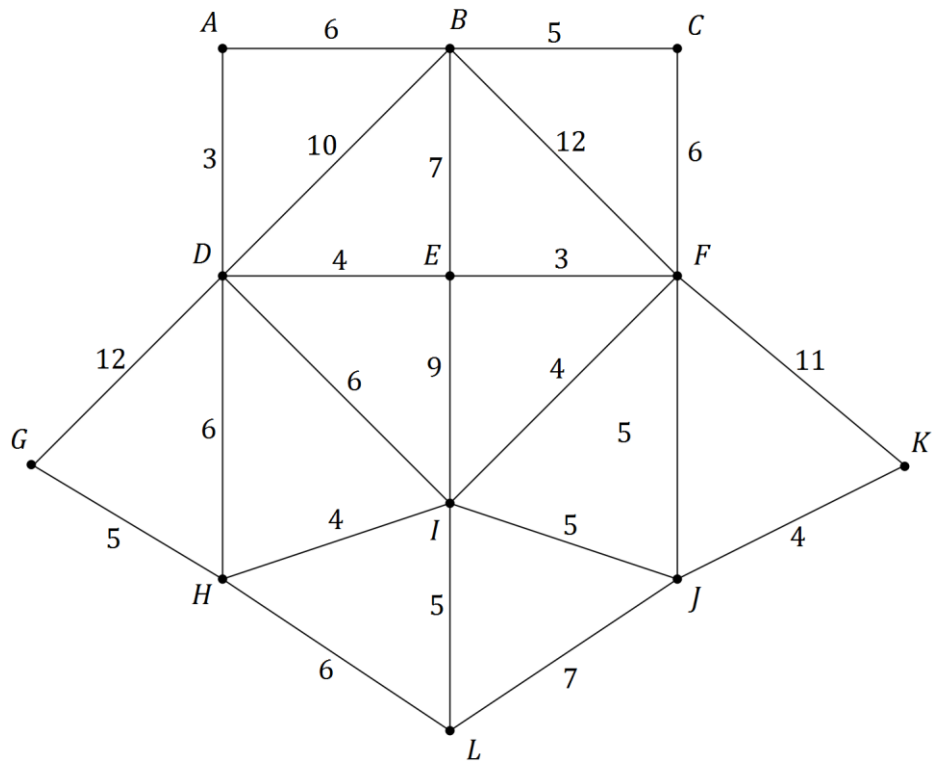

- (a) A taxi is required at junction B , and the two taxis currently available are at G and K . Determine which taxi will reach junction B first, justifying your answer by stating the minimum travel time and route for each taxi. (5 marks)

Question 16

(10 marks)

The number of orders for new homes that a building company received each quarter over the past three years is shown in the graph and table below.

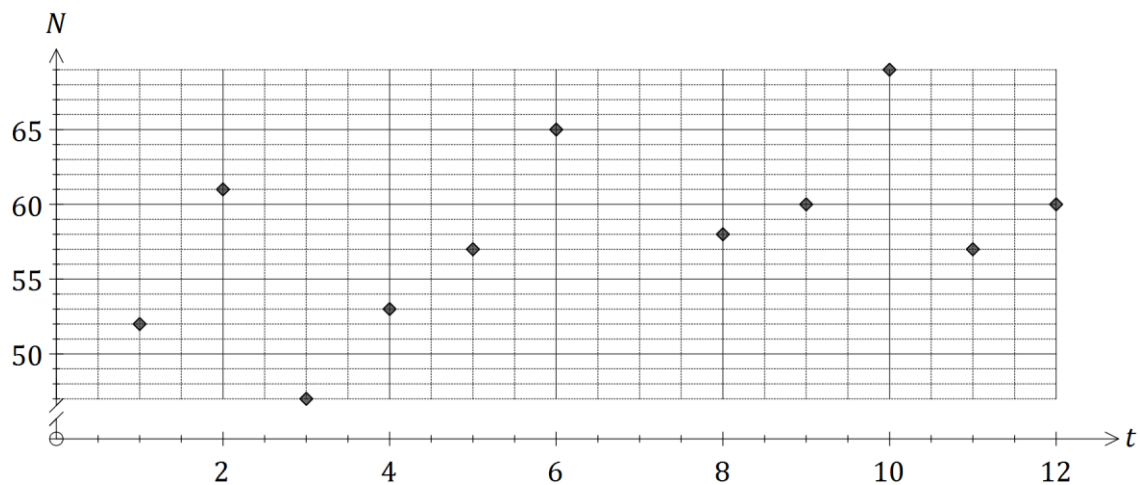

Year	Quarter	Time period (t)	Number of orders (N)	Yearly mean	Percent of yearly mean
2013	1	1	52	A	97.7%
	2	2	61		114.5%
	3	3	47		88.3%
	4	4	53		99.5%
2014	1	5	57	58.00	98.3%
	2	6	65		112.0%
	3	7	B		C
	4	8	58		100.0%
2015	1	9	60	61.50	D
	2	10	69		112.2%
	3	11	57		92.7%
	4	12	60		97.5%

- (a) Calculate the values of the entries **A**, **B**, **C** and **D** in the table. (4 marks)

- (b) Plot the number of orders received in the third quarter of 2014 on the graph. (1 mark)
- (c) Calculate the second quarter seasonal index and use it to deseasonalise the sales for the second quarter of 2015. (2 marks)
- (d) The trend in the deseasonalised number of homes, n , can be modelled by the line with equation $n = 0.935t + 51.509$. Forecast the actual number of homes that are likely to be ordered in the second quarter of 2016 if the above seasonality and trends continue. (3 marks)

Question 17

(7 marks)

An investor purchased a set of old coins for \$12 900, expecting the value of the set to increase by 5.5% each year.

(a) A recurrence relation that can be used to model the value, V_n , of the set of coins n years after they were bought is $V_{n+1} = V_n \times r$, $V_0 = a$.

(i) State the values of r and a in this relation. (2 marks)

(ii) Use the relation to calculate the expected value of the set of coins after five years, giving your answer to the nearest one hundred dollars. (2 marks)

(iii) How many years will it take for the value of the set of coins to double? (1 mark)

(b) The investor could have left the \$12 900 in a savings account paying interest of 5.3% per annum, compounded monthly. Determine the effective annual interest rate of this account and comment on whether the savings account would have been a better option for the investor. (2 marks)

Question 18

(8 marks)

The table below shows the number of people who cycled to work (n , in hundreds) and the average commute time for motorists (t , in minutes) for a small city over a number of years.

Year	2001	2002	2003	2004	2005	2006	2007	2008	2009	2010	2011
n	11	15	19	21	24	28	30	32	33	35	39
t	25	27	28	28	30	30	30	31	33	34	34

The least-squares line that models the linear relationship between the variables is $t = 0.317n + 21.73$ and the correlation coefficient is 0.966.

- (a) What percentage of the variation in average commute times can be explained by the variation in the number of cyclists? (1 mark)

The residual plot for the linear model is shown below.

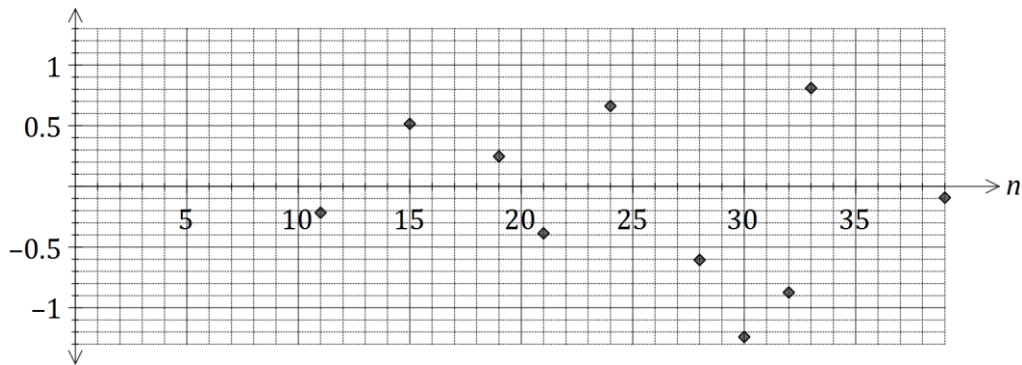

- (b) Calculate the missing residual for 2010 and plot it on the graph above. (3 marks)

- (c) Use the residual plot to explain whether fitting a linear model to the data is appropriate. (2 marks)

- (d) Can the above data be used to conclude that the variables n and t are causally related? Briefly explain your answer. (2 marks)

Question 19

(7 marks)

In a loan application office, incoming loans are reviewed at desk *A* and then move through various checks carried out at desks *B*, *C*, *D*, *E*, *F* and *G* before final approval is made at desk *H*. The weighted digraph below shows the maximum number of loans that can pass between desks during one working day.

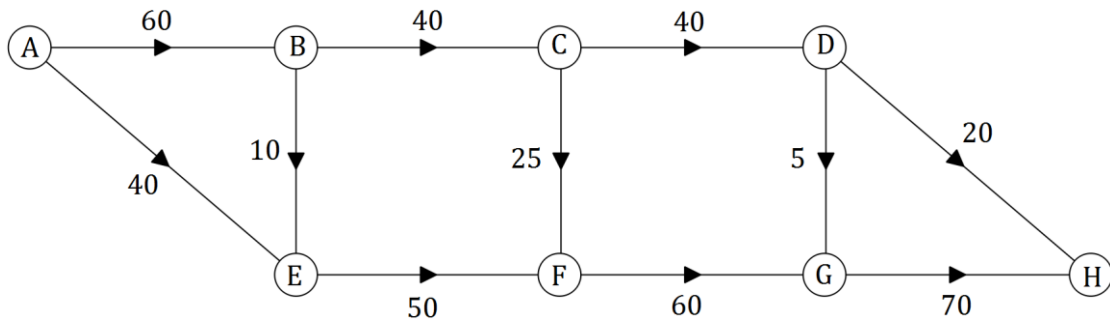

- (a) Determine, showing systematic working, the maximum number of loan applications that can be processed through the office in any one day. (3 marks)
- (b) Between which two desks does the largest spare capacity to move loan applications exist, and what is the spare capacity? (2 marks)
- (c) An internal review identified that more loan applications could be processed in a day by increasing the number currently transferred between just two of the desks. Which were the two desks identified and how many additional loan applications could be processed each day? (2 marks)

Question 20

(7 marks)

The value, V_n in hundreds of dollars, of a large computer system, n months after being purchased, can be modelled by a geometric sequence. The first few values are shown in the table below.

Month, n	0	1	2
Value, V_n (hundreds of dollars)	800	760	722

(a) Determine the percentage decrease in the value of the system each month. (2 marks)

(b) Use the information in the table to deduce a non-recursive rule for V_n in terms of n . (2 marks)

(c) Determine the decrease in value of the system one year after purchase. (2 marks)

(d) State, with reasons, whether the dollar decrease in value of the system during the second year will be the same, more, or less than the decrease over the first year. (1 mark)

Question 21**(8 marks)**

An annuity is set up with an initial sum of \$200 000 and guaranteed interest of 4.2% per annum, compounded monthly.

- (a) If regular monthly payments of \$950 are withdrawn at the end of each month, just after interest is added, the balance of the annuity, A_n , after n withdrawals, will be given by the recurrence relation $A_{n+1} = 1.0035 \times A_n - d$, $A_0 = 200000$.
- (i) Explain the relevance of the figure 1.0035 in this relation and state the value of d .
(2 marks)
- (ii) State the value of the annuity after six withdrawals.
(1 mark)
- (iii) Calculate the amount the total interest accrued by the annuity just after the 12th withdrawal.
(3 marks)
- (b) Determine the maximum monthly withdrawal that can be made if the annuity is to last
- (i) for exactly 12 years.
(1 mark)
- (ii) forever, that is, be a perpetuity.
(1 mark)

End of questions

Additional working space

Question number: _____

© 2016 WA Exam Papers. Trinity College has a non-exclusive licence to copy and communicate this paper for non-commercial, educational use within the school. No other copying, communication or use is permitted without the express written permission of WA Exam Papers.